



Deliverable Report

Ref.: DR_FRESH_ALGO

Vers.: version1

Status : Draft1

Date : 09/02/06

Page : 1 /10

Client : European Commission

Project : FRESH

Project N°: FP6-516059

Project Number: FP6-516059
Document number: FRESH_D2.2.1_Report-on-image-segmentationDeliverable report
Document Title: Report-on-image-segmentation
Document status: 09/02/06
Date: Confidential
Availability: Algo'Tech Informatique
Authors:

Abstract **This report summarizes the work done on Image segmentation of the Fresh WP2**

Keyword List WP2, image segmentation



Deliverable Report

Ref.: DR_FRESH_ALGO

Vers.: version1

Status : Draft1

Date : 09/02/06

Page : 2 /10

Client : European Commission

Project : FRESH

Project N°: FP6-516059

Image segmentation

1. INTRODUCTION	3
2. ERGONOMIC MAN MACHINE INTERFACE	3
3. CHOISE OF THE ANALYSIS METHOD : AUTOMATIC / SEMI AUTOMATIC	3
3.1. AUTOMATIC SOLUTION :	3
3.2. SEMI AUTOMATIC SOLUTION :	4
4. CODING THE IMAGE:	5
5. DETECTING THE LINES	5
5.1. SEPARATING THE JOINED OBJECTS	6
6. DETECTING THE BLOCKS	7
6.1. FORMING THE TEXT	7
6.2. FORMING THE SYMBOLS	8
7. SYSTEM AND DEVELOPMENT TOOLS	8
8. THE IMPLEMENTED CLASSES	9
9. CONCLUSION.....	10

Image segmentation

1. INTRODUCTION

The objective of this task is constituted by 3 main parts.

- Define the objects classes necessary to build a complete electrical CAD diagram.
- Implement the differents tools able to extract data from the picture.
- Define the most ergonomic man machine interface for the operator work optimisation.

At the end of this task, the segmentation data must be ready for the export to CAD environment.

2. ERGONOMIC MAN MACHINE INTERFACE

In this context, the effectiveness of computerized work cannot be restricted with the performance and the power of the data-processing tool.

The study of the ergonomic aspect makes it possible to propose convivial and innovating solutions adapted to the principal difficulties of the system. (density of information, superposition of various layers, symbols complexity...)

3. CHOISE OF THE ANALYSIS METHOD : AUTOMATIC / SEMI AUTOMATIC

In both cases, we supposes that the thresholding result is optimum. All the exploitable gray levels will have contributed to dissociate all the non dependent objects.

It can nevertheless remain some joining zones, which will be such as many difficults cases for the analysis tools.

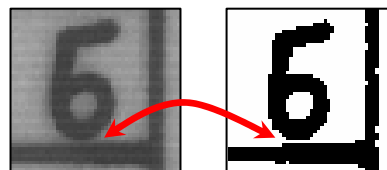

3.1. AUTOMATIC SOLUTION :

The quality of the documents which should be analyzed, lead to exclude an entirely automatic solution, requiring too many correction operations.

An erroneous decision at the analysis beginning, can induce many errors which the operators will have to rectify.

The manual analysis of a critical zone, makes it possible to avoid these errors propagations.



Deliverable Report

Ref.: DR_FRESH_ALGO

Vers.: version1

Status : Draft1

Date : 09/02/06

Page : 4 /10

Client : European Commission

Project : FRESH

Project N°: FP6-516059

3.2. SEMI AUTOMATIC SOLUTION :

To realize the segmentation, the operator must have the necessary tools for the extraction of the various objects of the document.

Every tool will carry out an automatic analysis of the selected part of the document, by observing rules and specific treatments of its function.

Consequently the progression in the general analysis of the document is done by step not requiring or little correction.

It is this operating mode which will be retained and implemented by the company Algo' Tech Informatique.

The analysis method chosen was defined as semi-automatic. Therefore, the operator must make choices as and when the processing progresses.

This means that the interface and tools ergonomics is important.

The document image analysis processes must be sequential and carried out chronologically in a defined order so that they can be optimised.

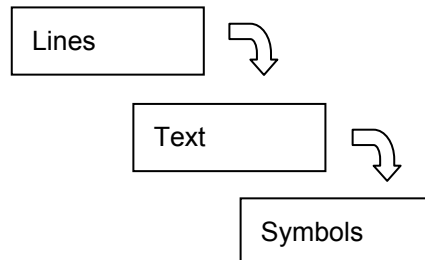

Each specialised tool is available in two operating modes.

A mode giving priority to the operator's decisions, in which only the local processes of separation and association are active.

A mode in which automation is more predominant and which analyses the simple areas quicker. In this option, texts and symbols are analysed simultaneously and classed according to their positions in relation to the equipotential lines already detected.

Construction rules, to impose or forbid certain configurations of the objects analysed, can be set by parameters.

- Constraints on the size of the elements of each of the three classes (segments, texts, symbols)
- Constraints on the thickness of segments.
- Constraints on proximity, including the limit distances of association according to the directions.
- Influence of proximity, such as forbidding the grouping of blocks on either side of a segment.

The analysis must extract its results from the image

- For the display interface that will present each class with a different colour.
- To provide the source for the text and symbol recognition modules.

The separation and association processes are applied during the extraction.

4. CODING THE IMAGE:

Whatever the source of the digitized document, the module's input format is bitmap.

The recommended standard digitization specifications are 300dpi, with 256 grey scales. The grey scales preserve the document's quality (good or bad).

However, the useful data is limited to two layers: the background and the diagram. The option of exploiting the grey scales before the analysis (at thresholding level), implies simpler analysis tools and a smaller amount of image data.

RLE coding is based on the notation of the black areas of each line of pixels.

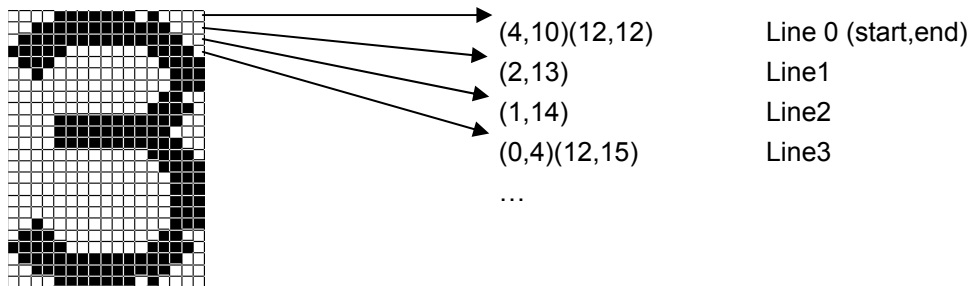

5. DETECTING THE LINES

The operator must designate the areas in the image from which the line detection tool should start in order to determine the starting points for analysis.

The area selected from the image is a strip perpendicular to the group of lines to be detected.

A local analysis, at the level of each intersection, triggers the following of each line.

At the same time, the portions of the image making up the line are recorded for the following extraction phase.

At each stage in the following of the line, a projection of the portion of the image is made and the line segment's validity deduced.

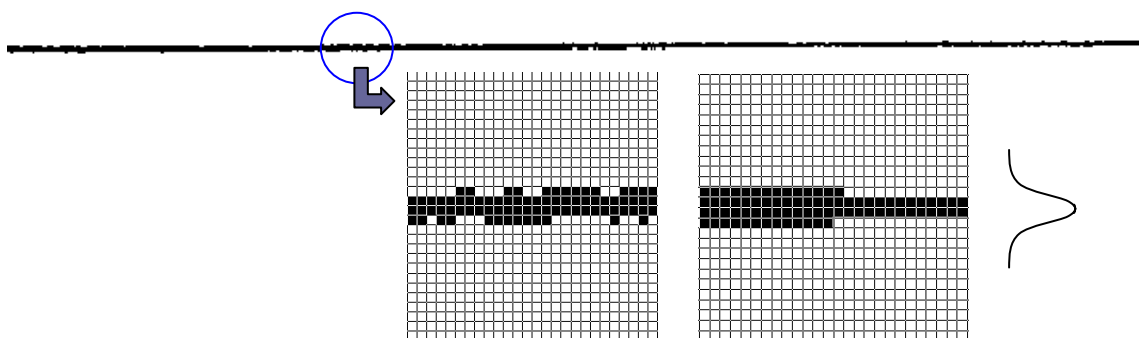



Deliverable Report

Ref.: DR_FRESH_ALGO

Vers.: version1

Status : Draft1

Date : 09/02/06

Page : 6 /10

Client : European Commission

Project : FRESH

Project N°: FP6-516059

The line is followed for as long as the sequence is not interrupted by an invalid segment (under certain tolerance conditions).

The data recorded for each line is then exploited in order to extract it. This must preserve the appearance of the objects that may be touched or crossed by a segment.

5.1. SEPARATING THE JOINED OBJECTS

The problems of joined objects usually involve one or more characters. They are either joined together or joined to objects from other families.

They have 2 main origins:

The choice of font, which may systematically join certain pairs of characters, and the successive deterioration of documents such as repeated photocopying, stains, yellowing, etc.

Whatever the thresholding applied, these different cases must be integrated into the detection tools.

The separation area must be processed to assign the pixels locally to each of the separated objects.

The joined configurations processed all involve a portion of a horizontal or vertical segment.

This will be found to be true in the majority of practical cases, for example, a text joined to the edge of a symbol or to an equipotential line.

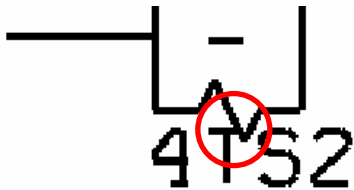

6. DETECTING THE BLOCKS

The next chronological stage: when the lines have been extracted from the document, the image's different blocks can be isolated, without distinguishing between them.

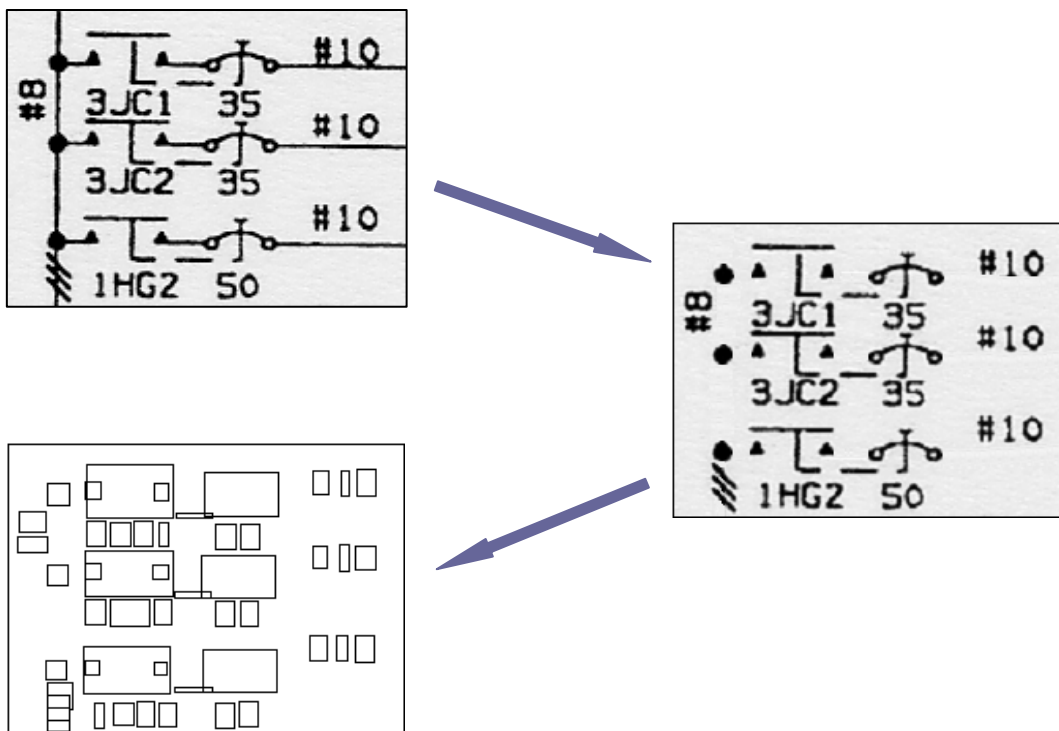

Some of these basic objects already represent a whole but the majority of them are simply part of an assembly that forms a word or a symbol.

This is the data that will be processed by the specialised analysis tools.

6.1. FORMING THE TEXT

When the simple blocks have been classified for the first time, the blocks assumed to be characters have been identified.

Therefore, the different elements still have to be associated with each other within this layer by applying the construction rules associated with the text.

The rules consider the form and the proximity arrangement of each isolated block in parallel.

The basic blocks are assumed to be characters and therefore, in the great majority of fonts used, their form can determine the orientation of the word in which they are used.

A few exceptions such as 'M' or 'W' in some fonts, or two joined characters (frequently the case when printing with some fonts) may contradict this rule.

To take these difficulties into account, several configurations are prepared and the solution proposed by the tool whose associations conform best to the rules imposed is chosen.

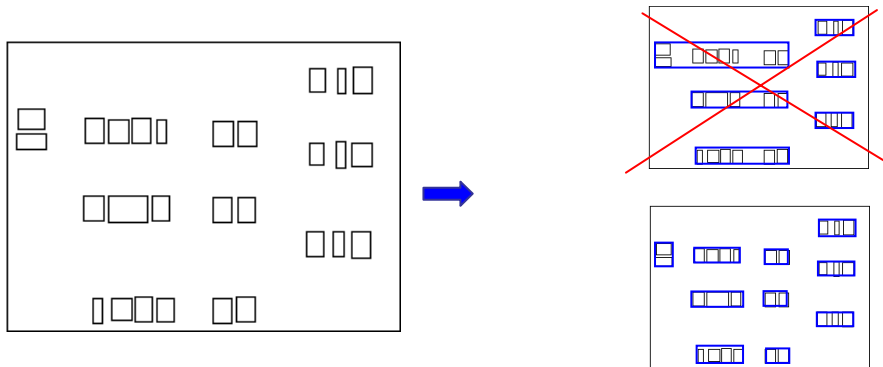

6.2. FORMING THE SYMBOLS

Generally, the symbols have the particularity of being connected to or positioned on one or more of the lines that are the equipotential lines.

This basic rule is used to make a first analysis of the blocks with the automatic tools.

But some are made up of several unrelated parts.

In which case, a tool that leaves the whole of the decision to the operator is chosen in order to force the analysis and thus avoid creating areas that need to be corrected.

7. SYSTEM AND DEVELOPMENT TOOLS

Algo' tech Informatique develops under the environment Windows 2K, XP, the code of the applications is produced in Delphi7, Delphi2005.



Deliverable Report

Ref.: DR_FRESH_ALGO

Vers.: version1

Status : Draft1

Date : 09/02/06

Page : 9 /10

Client : European Commission

Project : FRESH

Project N°: FP6-516059

8. THE IMPLEMENTED CLASSES

The basic object is the block of connex pixels. It is the first class to build. It only consider the neighbor pixels proximity. The followings algorithms will establish if a blocs must be joined to build most complex objects, or break up into its component parts,

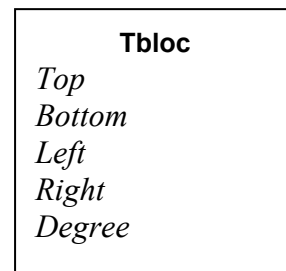

Blocks are used by the graphical interface to select and modify the elements during the analyse phase.

The mains objects which build up a electrical schematic document are lines of differents sorts, graphical symbols, and text.

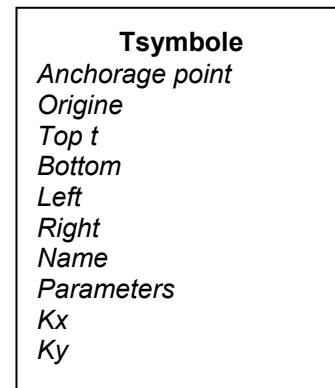
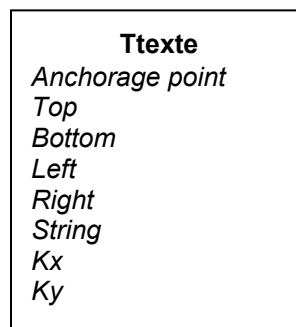
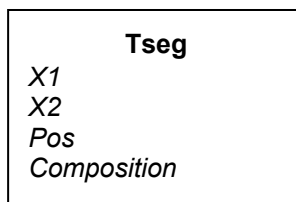

Any other classes are required to add to these mains objects.

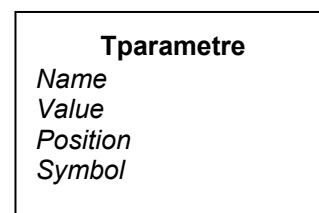
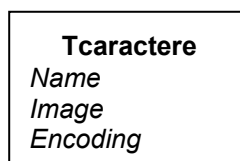
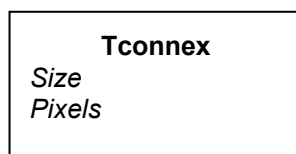



Deliverable Report

Ref.: DR_FRESH_ALGO

Vers.: version1

Status : Draft1

Date : 09/02/06

Page : 10 /10

Client : European Commission

Project : FRESH

Project N°: FP6-516059

9. CONCLUSION

The 3 main parts of this task are realized.

If we summarize the global work on the digitized document, the operator has available:

- An automatic thresholding to obtain the better quality source image.
- All the necessary tools to realize easily the total image segmentation.

The interactive interface allows the operator to make corrections after an automatic segmentation, and to manually process the difficult areas.